

DOC 302P - 302PS

- 5,5 m / 6,0 m - Voor tractoren 80-110 pk / For tractors 80-110 hp

ACHTEROP GEPLAATSTE ARMMAAIER
REAR HEDGE MOWERS



DOC 302P	Prijs op aanvraag
DOC 302PS	Prijs op aanvraag

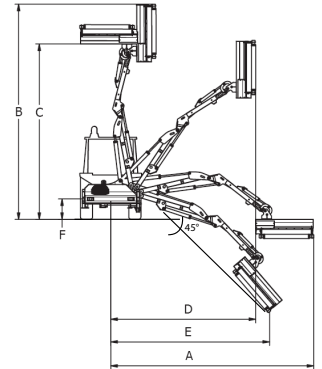

DOC 302	P	PS
A (mm)	5.500	6.000
B (mm)	5.700	6.200
C (mm)	4.600	4.700
D (mm)	4.500	5.000
E (mm)	3.700	4.200
F (mm)	550	550

Hydraulische bosmaaier met arm met side shift en 90° achterwaartse rotatie met schokbestendige hydraulische beveiliging voor tractoren van 80/110 pk en 3500/4500 kg gewicht, ideaal voor werkzaamheden in stedelijke gebied en langs buitenwegen en voor agrarische bedrijven.

Hydraulic hedge mower with side shift and 90° rotating column with shock resistant hydraulic safety device for tractors HP 80/110 and weight 3500/4500 kg, suitable for working on local and trunk roads and farms.

ARM MAAIER - ARM MOWER

TRACTOR - TRACTOR

Model Model	Reikwijdte Extension E (mm)	Gewicht Weight (kg)	Olietank Oil tank (L)	Type kop Head (model)	Pomp Pump (l/min)	Hydr. Motor Hydraulic Motor (HP [kW])	Vermogen Power (HP [kW])	3 punts ophan- ging 3-point linkage	Gewicht Weight (kg)	Breedte Width (m)	PTO (t/m) (rpm)
DOC 302 P	5.500	1.250	160	30.4 TTD	100+20	55 (40)	80 / 110	Cat. 2	3.500	2,4	540
DOC 302 PS	6.000	1.300	160	30.4 TTD	100+20	55 (40)	80 / 110	Cat. 2	4.000	2,4	540



P

P-type: Mechanisme waarmee u tegelijk met het wiel kunt werken voor werken met lange uitschuifdelen, met behoud van goede snelheid en wendbaarheid.

P: Mechanism that allows to work flush to the wheel with long extension machines, with a very-good speed and handling quickness.



S

S-type: Met telescoop arm.
S: With telescopic arm/s.

TECHNISCHE SPECIFICATIES EN STANDAARD UITRUSTING

- Frame – 1e en 2e arm uitgevoerd in hoogwaardig staal ST.52
- Colonna di rotazione a 90° e sicurezza idraulica antiurto
- Drie punts ophanging CAT2
- Hydrauliek olietank 160 liter
- Dubbele tandwielgroep groep 3+2 - 100+20 lt/min
- Bidirectionele hydro motor, vermogen 55 PK
- Kabelbediening met remote control, flexibele kabel, 3000 mm
- Zwevend zelfnivellerend systeem
- Looprol verstelbaar in 3 standen
- Draaihoek van de maaikop 200° met bovenaansluiting
- Spiraalvormige rotor met onderbroken snijmes - KC4
- Rotorsnelheid 3000 tpm
- Spanner bevestiging- Giunto cardanico
- Scambiatore di calore aria-olio con massa radiante ad elevato scambio termico
- Achterbalk met verlichting
- Klepelmaaier 1300 mm MODEL 30.4 TTD 130 met directe overbrenging

TECHNICAL FEATURES AND STANDARD EQUIPMENT

- Frame - 1st arm - 2nd arm in structural steel ST 52
- 90° rotating column and shock resistant hydraulic safety device
- Three points attachment 2nd category
- Oil tank 160 l
- Double gear pump group 3+2 - 100+20 l/min
- Bidirectional hydraulic motor HP 55 power
- Distributor with remote controls with mm 3000 flexible cables
- Self-levelling floating system
- Feeler roller recordable on 3 positions
- Head rotating angle 200° with upper attachment
- Helicoidal rotor with jointed cut blade KC4
- Number revs to rotor 3000 rpm
- Fixing tie-rods - Cardan joint
- Air-oil heat exchanger with radiating mass at high thermal exchange
- Rear underrun protection with lights
- Flail head mm 1300 MODEL 30.4 TTD 130 with direct transmission



KC4

Ø max 2 cm

Standaard uitrusting
standard equipment

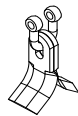

KC5

Ø max 2 cm



HC2

Ø max 4 cm

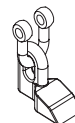

HF4

Ø max 6 cm



KF4

Ø max 4 cm



KF5

Ø max 4 cm

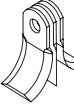

KF6

Ø max 3 cm



HF5

Ø max 6 cm



OPTIES OP AANVRAAG / MEERPRIJS

- Maaikop 30.3 (DOC302)
- Stikstofaccumulator voor 1e armophanging
- Klepelmaaier 1050 mm
- Klepelmaaier zwaar type, model 30.5
- Aan/Uit elektro-hydraulische bediening met joystick
- Riemoverbrenging "TTC" Zwaar model 30.5
- Proportionele servo met joystick
- Aankoppeling adapter CAT 1-2

ACCESSORIES ON REQUEST

- Flail head 30.3 (DOC 302)
- Nitrogen accumulator for 1st arm suspension
- Flail head mm 1050
- Flail head, type heavy, Mod. 30.5
- On-off electro-hydraulic distributor with joystick
- Belt transmission "TTC", type heavy, Mod. 30.5
- Power-assisted with joystick
- Tie rods adapter Cat. 1 o 2

AANKOPPELGEREEDSCHAP - TER VERVANGING VAN DE STANDAARD KLEPELMAAIER | TERMINAL TOOLS - IN REPLACEMENT OF THE STANDARD MULCHER

HEGGEN TRIMMER

HEDGE CUTTING BAR

BF15

TAKKEN SNIJDER

BRANCH CUTTING BAR

BTZ5 15

BTZ5 18

BTZ10 16

BTZ10 19

BTZ10 22

BOSMAAIER SCHIJVEN

FOREST DISCS CUTTING BAR

BD2

BD3

SCHIJVEN BOSMAAIER

DISC BRANCH CUTTER

DFG12

GREPPEL REINIGER

DITCH CLEANER

PF60



BF15



BTZ5/10



BD2/3

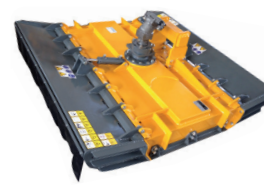

DFG12



PF60